

PDK Calibration Guide v2.5

For Porsche PDK 911/Boxster/Cayman 997/991/987/981/718

Sometimes calibration can be a challenge. This guide is a compilation of the collective knowledge to pass calibration in PIWIS/AUTEL tool.

Correct PDK Disassembly/Assembly

When doing PDK repairs for the first time - please use your time and study this entire Rennlist thread. It is a good example of the process

<https://rennlist.com/forums/997-forum/1256814-repairing-my-pdk-gearbox-experience-and-guide.html>

It is vital to use a puller tool to open PDK. There is drawing of puller tool in post #5, and a good example picture in post #73. Puller tool is also available on Ebay as “PDK Housing Disassembly Tool”.

Less obvious, but equally important to do this process in reverse **when closing PDK**. Pull shafts into bearings by pulling at shafts ends until the case is closed, and only then do the perimeter bolts. **Do not** use/rely on perimeter bolts to push shafts into the bearings. If not done properly, there will be tension inside of the mechanism, and that will prevent successful calibration.

PIWIS Version

PIWIS version seems to be important for calibration. PIWIS v2 is reported to have more success than PIWIS v3. Although it is known to use v3 and pass calibration, **multiple** shops reported that v2 worked after many attempts with v3 failed.

And one shop reported using PIWIS v4 and calibrating on a first attempt, after both v2 and v3 failed to calibrate multiple times. So it seems that v2 and v4 are the best. Try to avoid v3 if possible. It is certain that trying different versions of PIWIS can help pass calibration.

We also know of cases where the same version of PIWIS, but from a different computer helped pass calibration. So if you can borrow another PIWIS somewhere - it is worth a try.

Oil Spec and Bleeding Procedure

We strongly recommend to use this oil for the transmission and **NOTHING ELSE:**
ATF transmission oil Mobilube PTX Formula A (SAE 75W-90) GL 4.5

It is very important to complete the “Oil filling” procedure before calibration. It will get rid of air bubbles in the hydraulic system, which improves response to hydraulic inputs.

Throttle Body Calibration

It is recommended to perform Throttle Body Calibration before starting the PDK calibration. It is known to increase the chances of PDK calibration.

Update Programming of the DME and PDK TCU

Forced PDK software update was reported to help in many many cases. Therefore we suggest to do it right away and don't waste time trying without it.

It's in the PIWIS menu -> Diagnostics -> Transmission Control -> Programming, Automatic Programming -> Unit Documentation -> PDK and DME and follow the prompts.

Your tool menus can be different. Just look for Software update for PDK/TCU and DME.

Do not assume that PIWIS will do this update automatically for you. PIWIS sometimes can do some updates, but this is not part of those updates. You have to initiate this update in the menu.

It is important to keep both PIWIS and CAR on a charger during this procedure.

Always Calibrate WITHOUT Replacement (short calibration)

There are two types of calibration procedures in PIWIS. The LONG calibration and SHORT calibration.

The LONG version ("WITH part replacement") is for complete rebuild of PDK. It has many steps that go over every major component:

1. TCU cleared and reprogrammed
2. Pressure sensor calibration
3. Shift rods calibration (distance sensor)
4. Hydraulics calibration/learning
5. Clutch calibration

The SHORT version ("WITHOUT part replacement") only does

3. Shift rods calibration (distance sensor)
5. Clutch calibration

Do NOT think of those two versions as equal choices to play with. Long calibration is a WRONG choice when only distance and/or speed sensors were replaced. **Always use SHORT calibration ("WITHOUT replacement") when distance and/or speed sensors were the only parts replaced.** It is a much simpler procedure. It assumes that nothing else changed in the PDK, and so there are fewer steps in the program, and fewer possibilities to fail. Make sure to give it at least 10 tries, as mentioned in the previous chapter.

Only use LONG (“WITH replacement”) if the valve body was replaced and/or if everything else fails to make PDK working after many attempts. The LONG calibration tends to get stuck on hydraulics step, and one can end up with wiped out TCU, where previous setup was deleted and new one was not created.

NOTE: Once the LONG calibration was called, there is no point in trying SHORT calibration later. LONG calibration erases all the previous data, and SHORT calibration will not pass after that, usually failing on the “Hydraulics Teaching” step.

Disconnect the Battery

If everything else failed - disconnect the car battery overnight and repeat the calibration attempts after 8 hours.

Aftermarket PCM (Radio)

At least for 987 model: If there’s an aftermarket radio installed - the gateway will log a fault and prevent the PDK calibration from going through at all. To fix this - the gateway has to be coded to have radio “not installed”.

Number of Calibration Attempts

Calibration almost never finishes on the first attempt. It is normal to try at least 8 times after all the recommendations that listed above. Many shops reported calibration on the 8th attempt. One shop had success on the 13th attempt.

Improper Seating of the Shafts Into Bearings

THE MOST COMMON PROBLEM IF EVERYTHING ELSE FAILS

Sometimes nothing seems to work. In most of the cases the problem is that the shaft is not quite where it should be in relation to other moving parts of PDK, and that creates stress. It can be by the very small amount, but just a 1mm off can create stress that will prevent actuators to be able to move freely in the range necessary.

Few words about internals of PDK:

It is basically a manual gearbox, where human input is replaced by actuators.

There are two input shafts with a clutch on each shaft. Each shaft serves two “channels” (in PDK speak). Four “channels” in total.

Each “channel” is an assembly of Actuator, Linkage and Shift Fork. Actuators pull/push the Shift Fork. Shift Fork engages one of the two gears on that “channel”. So eight gears in total on four channels. Seven forward gears plus reverse.

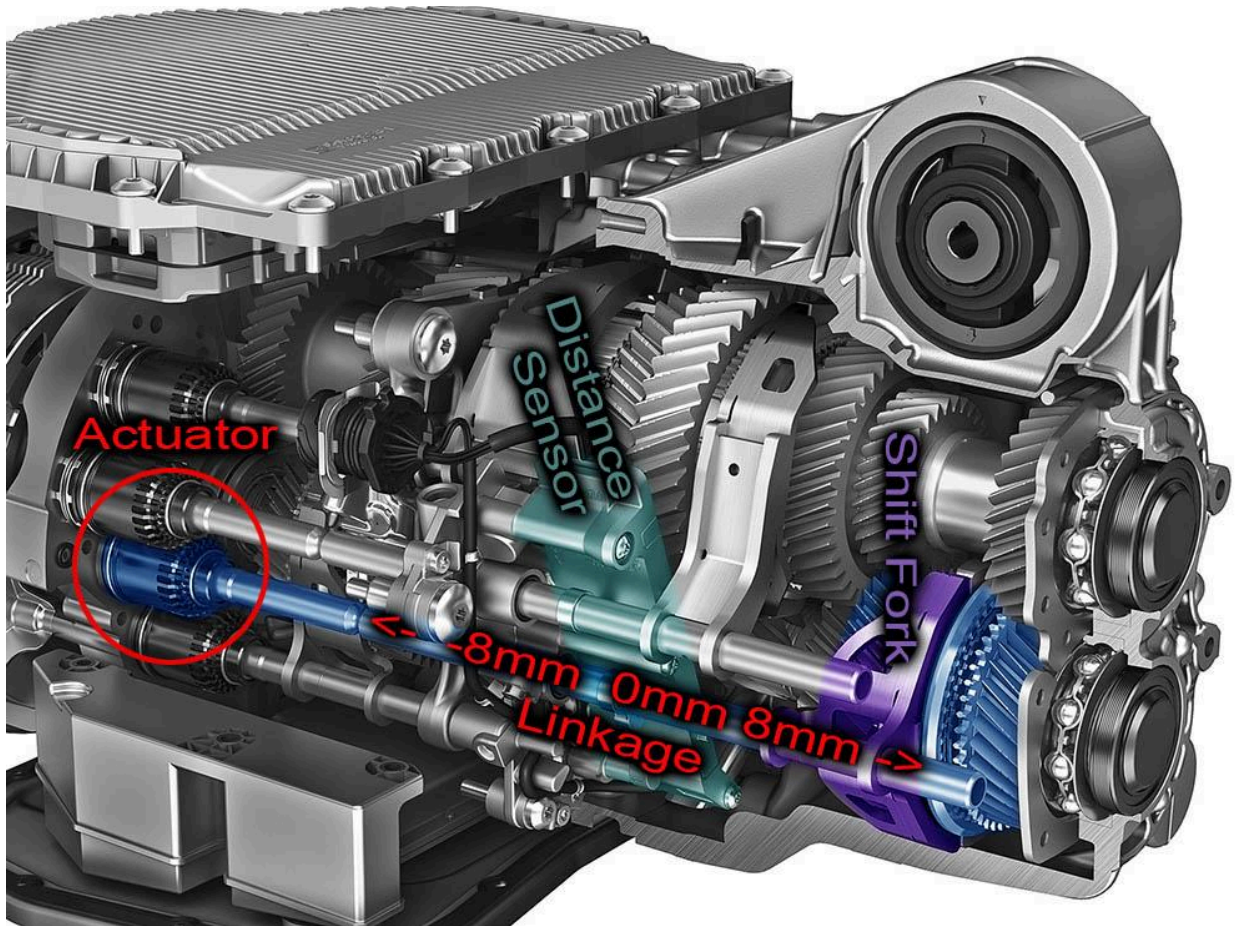

The function of the Distance Sensor is to read the position of the Shift Fork and report it to TCU. This way TCU knows what gear is engaged. -8mm indicates one gear on the “channel”, 8mm indicates another gear on the “channel”, and 0mm indicates central position or neutral.

As it was already mentioned above, it’s very important to close the PDK case by pulling on the shafts. Even then it’s sometimes more art than science. If something didn’t click right - the introduced stress in the system will prevent the actuator from doing it’s job - pushing or pulling Shift Fork by 8mm. The gear will not be able to engage, and TCU will correctly assume that things are not good, and cancel calibration.

If you are able to see the channel values in PIWIS, you will see other values than +/- 8mm. The normal values should be 0mm, 8mm or -8mm, with +/- 1mm acceptable variations. If you see smaller values, like 5mm or 6mm, that means that channel is stressed and can not move all the way to 8mm, and the gear can not be engaged.

The solution is to open and close PDK again making sure shafts are in the right position. Multiple calibration attempts sometimes do the same thing naturally - helps the linkage to relieve stress and work itself into the right position so it is now able to move freely all the way.

Full Range of Errors, Aftermarket Sensors and Connectors Pinout

There is a chance that mistake was made during splicing.

There is also a chance that the sensor has been previously replaced by an aftermarket sensor of unknown origin. Those are prone to failing and will require replacement again.

Non-OEM sensors of unknown origin might not follow OEM wiring colors and positions. If an unknown aftermarket sensor was used for splicing reference for installing T-Design sensor - it will produce unpredictable results. Usually errors on all channels like in the picture below:

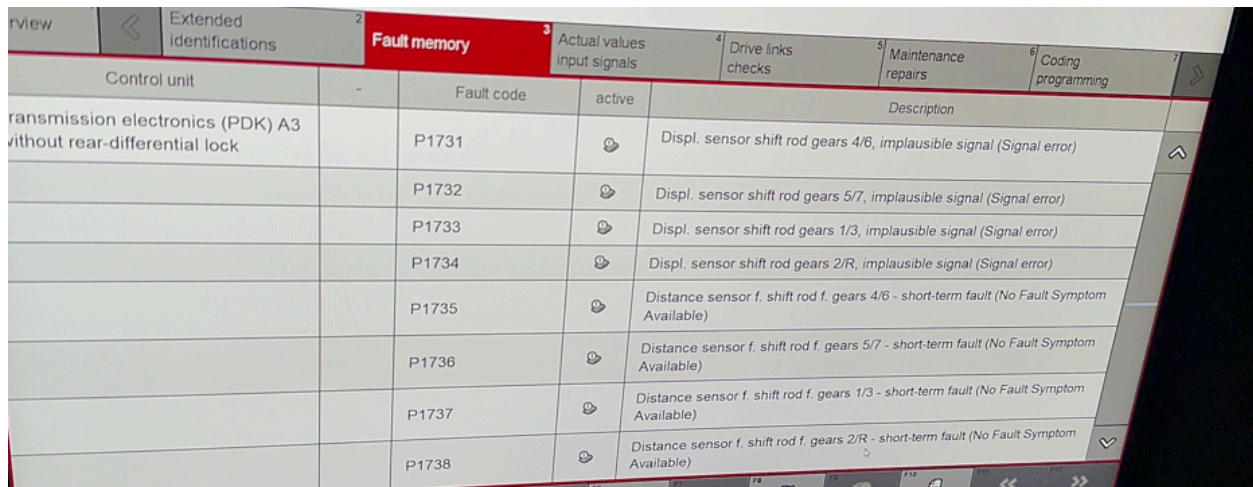

All our sensors are thoroughly tested at the factory. The only explanation for this full range of sensor errors is that the sensor is not getting the power. Same as not having a Distance Sensor installed at all. This is caused by incorrect wiring.

If after installation you see the screen full of errors like above - trace the wires back from the round plug to the T-Design sensor and check against the pinout below:

Sensor	OEM Sensor Position/Color	T-Design Pin	OEM Round Plug Pin
Distance	1 - Gray	1	9
Distance	2 - Red	2	12
Distance	3 - Black	3	13
Distance	4 - Yellow	4	10
Distance	5 - White	5	8
Distance	6 - Green	6	7
Speed	1 - Gray	1 (Same as OEM)	4
Speed	2 - Green	2 (Same as OEM)	5
Speed	3 - Red	3 (Same as OEM)	3

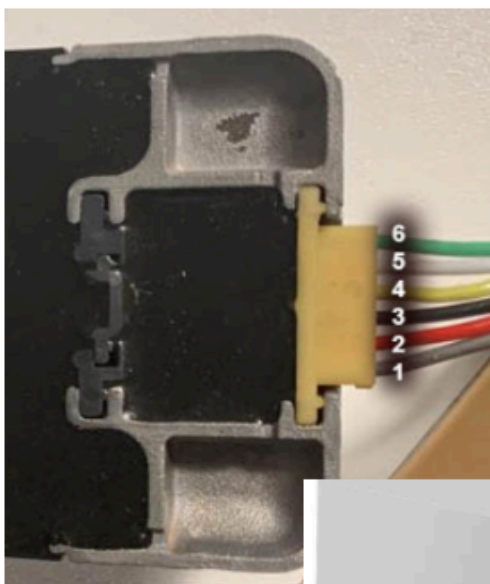

OEM

